

4" 95 PR8
95 PRX8
95 PRG8

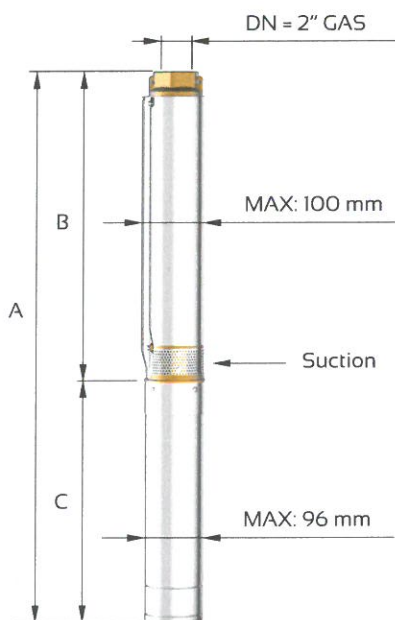

Caratteristiche idrauliche/Hydraulic performances

Motore - Motor - Moteur 50 Hz - 2900 rpm						Q = Portata - Capacity - Debit								
Tipo - Type	Power		Mono Phase Single phase V230		V 400	I/min	0	80	100	120	140	160	180	200
	kW	HP	A	µF	A	I/sec	0	1,33	1,67	2,00	2,33	2,67	3,00	3,33
							0	4,8	6	7,2	8,4	9,6	10,8	12
95 PR8 N/04	0,75	1	6,5	30	2,2	H[m]	27	25	23	22	20	17	14	10
95 PR8 N/07	1,10	1,5	9,6	40	3,1		47	44	40	39	35	30	25	18
95 PR8 N/09	1,50	2	11,8	50	4		61	56	52	50	45	38	32	23
95 PR8 N/13	2,20	3	15,2	75	5,8		88	81	75	72	65	55	46	33
95 PR8 N/17	3	4	-	-	7,5		115	106	98	94	85	72	60	43
95 PR8 N/23	4	5,5	-	-	9,8		155	144	132	127	115	98	81	58
95 PR8 N/31	5,50	7,5	-	-	13,5		209	194	178	171	155	132	109	78
95 PR8 N/42	7,50	10	-	-	17,5		284	263	242	231	210	179	147	105



Motore - Motor - Moteur 50 Hz - 2900 rpm	Dimensioni di ingombro e pesi Overall dimensions and weights							
Tipo - Type	A mm Mono V230M	A mm Tri V400	B mm	C mm Mono	C mm Tri	M kg Mono	M kg Tri	P kg
95 PR8 N/04	643	618	281	362	337	10	10	3
95 PR8 N/07	763	733	371	392	362	12	12	4
95 PR8 N/09	853	823	431	422	392	13	13	4,5
95 PR8 N/13	1040	1025	573	467	452	15	15	6
95 PR8 N/17	0	1250	693	0	557	0	19	7,5
95 PR8 N/23	0	1470	873	0	597	0	22	8,5
95 PR8 N/31	0	1833	1135	0	698	0	27	11
95 PR8 N/42	0	2305	1487	0	818	0	32	15

Versioni disponibili
Available versions
Versions disponibles
Versiones disponibles



95 PRX

Gabbia di aspirazione e mandata in AISI 304 microfuso



Suction cage and delivery bowl in AISI 304 casted



95 PR

Gabbia di aspirazione e mandata in ottone



Suction cage and delivery bowl in brass



95 PRG

Gabbia di aspirazione e mandata in ghisa con trattamento di cataforesi



Suction cage and delivery bowl in cast iron with CED (Cathode Electro Deposition)

n% = Rendimento della pompa Max 69%
W/st = Assorbimento per stadio Max 174

n% = Rendement de la pompe Max 69%
W/st = Absorption par étage Max 174

n% = Pump efficiency Max 69%
W/st = Stage absorption Max 174

n% = Rendimiento de la bomba Max 69%
W/st = Potencia absorbida por etapa Max 174

MEI ≥ 0,4 (direttiva EU No. 547/2012 - regulation EU N. 547/2012)
Tolleranze secondo UNI ISO 9906 livello 3B - Tolerances according to UNI ISO 9906 grade 3B