

4" 95 PR6
95 PRX6
95 PRG6

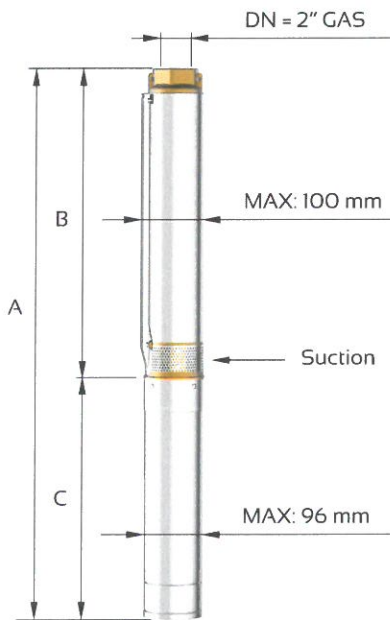

Caratteristiche idrauliche/Hydraulic performances

Motore - Motor - Moteur 50 Hz - 2900 rpm						Q = Portata - Capacity - Debit								
Tipo - Type	Power		Mono Fase Single phase V230		V 400	l/min	0	40	60	80	100	120	140	160
	kW	HP	A	μF	A	l/sec	0	0,67	1	1,33	1,67	2	2,33	2,67
						m ³ /h	0	2,4	3,6	4,8	6	7,2	8,4	9,6
95 PR6 N/O4	0,55	0,75	5	20	1,7	H[m]	27	24	23	22	19	17	13	10
95 PR6 N/O6	0,75	1	6,5	30	2,2		41	36	35	33	29	26	20	15
95 PR6 N/O9	1,10	1,5	9,6	40	3,2		61	54	52	50	43	38	29	23
95 PR6 N/13	1,50	2	11,8	50	4		88	78	75	72	62	55	42	33
95 PR6 N/17	2,20	3	15,2	75	5,9		115	102	98	94	81	72	55	43
95 PR6 N/23	3	4	-	-	7,8		155	138	132	127	109	98	75	58
95 PR6 N/31	4	5,5	-	-	9,8		209	186	178	171	147	132	101	78
95 PR6 N/42	5,50	7,5	-	-	13,5		284	252	242	231	200	179	137	105
95 PR6 N/56	7,50	10	-	-	17,5		378	336	322	308	266	238	182	140



Motore - Motor - Moteur 50 Hz - 2900 rpm	Dimensioni di ingombro e pesi Overall dimensions and weights							
Tipo - Type	A mm Mono V230M	A mm Tri V400	B mm	C mm Mono	C mm Tri	M kg	M kg Tri	P kg
95 PR6 N/O4	618	598	281	337	317	8	8	3
95 PR6 N/O6	703	678	341	362	337	10	10	3,5
95 PR6 N/O9	823	793	431	392	362	12	12	4,5
95 PR6 N/13	995	965	573	422	392	13	13	6
95 PR6 N/17	1160	1145	693	467	452	15	15	7,5
95 PR6 N/23	0	1430	873	0	557	0	19	8,5
95 PR6 N/31	0	1732	1135	0	597	0	22	11
95 PR6 N/42	0	2185	1487	0	698	0	27	15,5
95 PR6 N/56	0	2747	1929	0	818	0	32	20

Versioni disponibili
Available versions
Versions disponibles
Versiones disponibles



95 PRX
Gabbia di aspirazione e mandata in AISI 304 microfuso
Suction cage and delivery bowl in AISI 304 casted

n% = Rendimento della pompa Max 68 %
W/st = Assorbimento per stadio Max 118
n% = Rendement de la pompe Max 68 %
W/st = Absorption par étage Max 118



95 PR
Gabbia di aspirazione e mandata in ottone
Suction cage and delivery bowl in brass



95 PRG
Gabbia di aspirazione e mandata in ghisa con trattamento di cataforesi
Suction cage and delivery bowl in cast iron with CED (Cathode Electro Deposition)

n% = Pump efficiency Max 68%
W/st = Stage absorption Max 118
n% = Rendimiento de la bomba Max 68%
W/st = Potencia absorbida por etapa Max 118

MEI ≥ 0,4 (direttiva EU No. 547/2012 - regulation EU N. 547/2012)
Tolleranze secondo UNI ISO 9906 livello 3B - Tolerances according to UNI ISO 9906 grade 3B